

## DIN 8167 FÖRDEYER ZİNCİRLERİ (M SERİSİ)

### DIN 8167 SOLID BEARING PIN CONVEYOR CHAINS (M SERIES)

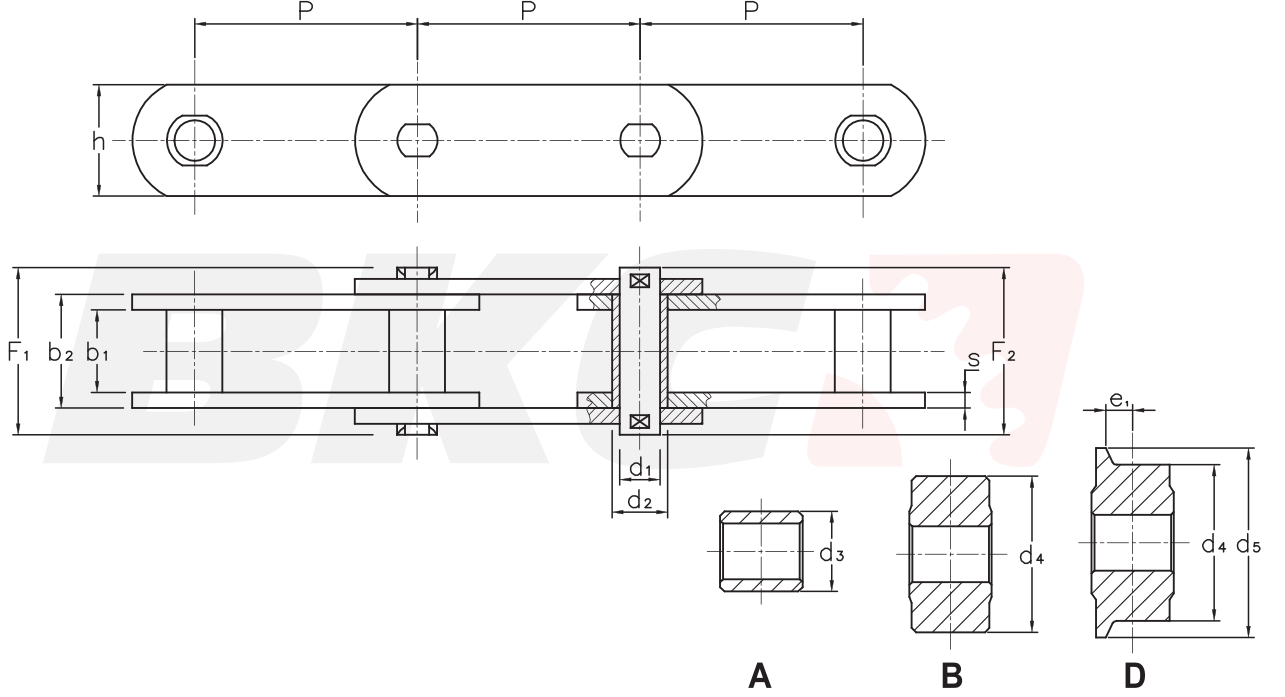

\*\* Pim ve İç Burç (Anahtar ağızlı değildir) \*\* Pim+Bushed (Notfatted)

ISO Nr. ISO No.	p mm		b <sub>1</sub> mm min.	b <sub>2</sub> mm max.	d <sub>1</sub> mm	d <sub>2</sub> mm	d <sub>3</sub> mm A	d <sub>4</sub> mm B	d <sub>4</sub> /d <sub>5</sub> mm D	e <sub>1</sub> mm	F <sub>1</sub> mm	F <sub>2</sub> mm	h mm	s mm	F <sub>B</sub> N min.
M 20**	40	50	16	22	6	9	12,5	25	25/30	4	31,2	36,2	18	2,5	20000
	63	80													
	100	125													
	160														
M 28**	50	63	18	25	7	10	15	30	30/36	4,5	35,2	40,2	20	3	28000
	80	100													
	125	160													
	200														
M 40**	63	80	20	28	8,5	12,5	18	36	36/42	4,5	40,2	47,2	25	3,5	40000
	100	125													
	160	200													
	250														
M 56	63	80	24	33	10	15	21	42	42/50	6	47,2	56,2	30	4	56000
	100	125													
	160	200													
	250														
M 80	80	100	28	39	12	18	25	50	50/60	7	55,2	64,2	35	5	80000
	125	160													
	200	250													
	315														
M 112	80	100	32	45	15	21	30	60	60/70	7,5	64,2	75,2	40	6	112000
	125	160													
	200	250													
	315	400													

Numune ve teknik resim esaslı her türlü özel zincir üretimi yapılır. *Production based on a given sample or a technical drawing.*

## DIN 8167 FÖRDEYER ZİNCİRLERİ (M SERİSİ) DIN 8167 SOLID BEARING PIN CONVEYOR CHAINS (M SERIES)

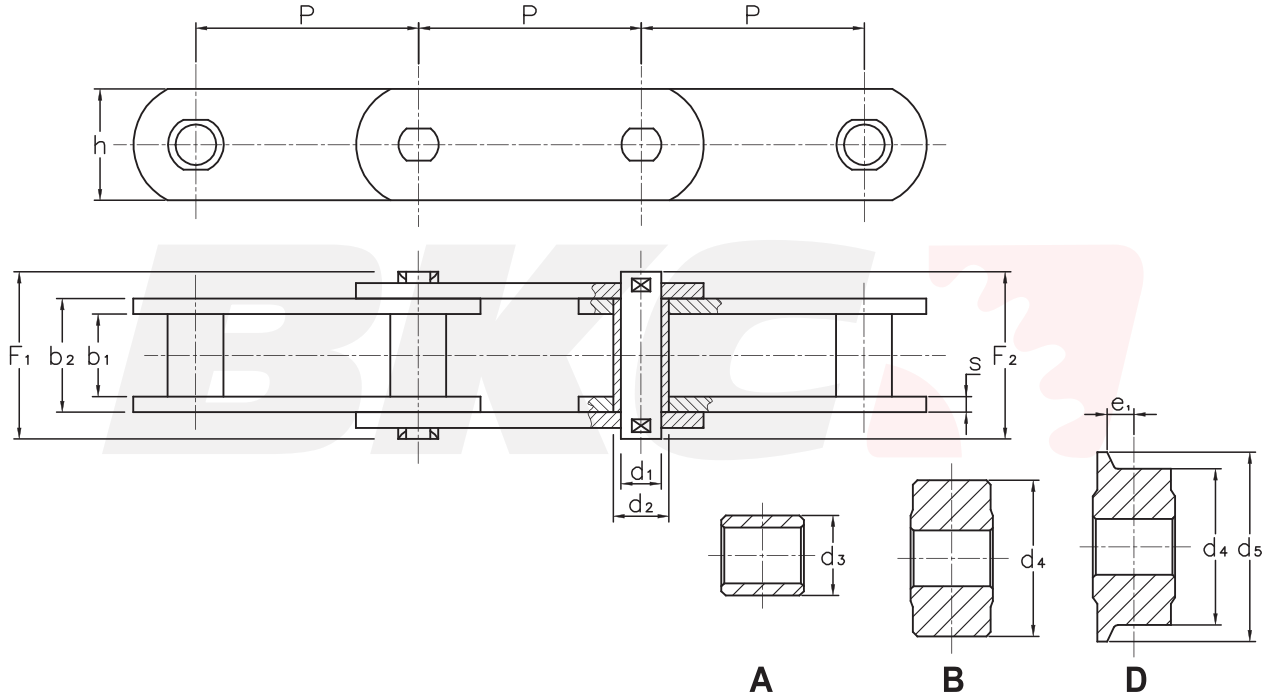

\* Döküm \* Cast iron

ISO Nr. ISO No.	p mm	b <sub>1</sub> mm min.	b <sub>2</sub> mm max.	d <sub>1</sub> mm	d <sub>2</sub> mm	d <sub>3</sub> mm A	d <sub>4</sub> mm B	d <sub>4</sub> /d <sub>5</sub> mm D	e <sub>1</sub> mm	F <sub>1</sub> mm	F <sub>2</sub> mm	h mm	s mm	F <sub>B</sub> N min.	
M 160	100	125	37	52	18	25	36	70	70/85	8,5	73,3	88,3	50	7	160000
	160	200													
	250	315													
	400	500													
M 224	125	160	43	60	21	30	42	85	85/100	10	86,3	99,3	60	8	224000
	200	250													
	315	400													
	500	630													
M 315	160	200	48	70	25	36	50	100	100/120	10,5	100,3	120,3	70	10	315000
	250	315													
	400	500													
	630														
M 450	200	250	56	82	30	42	60	120	120/140*	11,5	117,3	141,3	80	12	450000
	315	400													
	500	630													
	800														
M 630	250	315	66	96	36	50	70	140	140/170*	14,5	136,3	159,3	100	14	630000
	400	500													
	630	800													
	1000														
M 900	250	315	78	112	44	60	85	170	170/210*	17	157,3	179,3	120	16	900000
	400	500													
	630	800													
	1000														

Numune ve teknik resim esaslı her türlü özel zincir üretimi yapılır. *Production based on a given sample or a technical drawing.*

## DIN 8168 PİM MAKARALI FÖRDEYER ZİNCİRLERİ (MC SERİSİ) DIN 8168 HOLLOW BEARING PIN CONVEYOR CHAINS (MC SERIES)

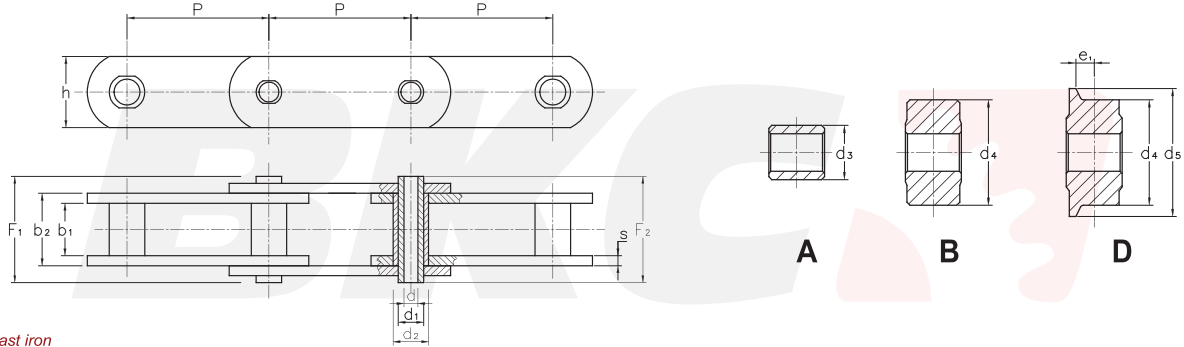

\* Döküm \* Cast iron

ISO Nr. ISO No.	p mm		b <sub>1</sub> mm min.	b <sub>2</sub> mm max.	d <sub>1</sub> mm	d <sub>2</sub> mm	d <sub>3</sub> mm A	d <sub>4</sub> mm B	d <sub>4</sub> /d <sub>5</sub> mm D	d mm	e <sub>1</sub> mm	F <sub>1</sub> /F <sub>2</sub> mm	h mm	s mm	F <sub>B</sub> N min.	
MC 28	63	80	100	20	28	13	17,5	25	36	36/42	8,2	4,5	40,6	25	3,5	28000
	125	160														
MC 56	80	100	125	24	33	15,5	21	30	50	50/60	10,2	6,0	46,6	35	4	56000
	160	200	250													
MC 112	100	125	160	32	45	22	29	42	70	70/85	14,3	7,5	63,8	50	6	112000
	200	250	315													
MC 224	160	200	250	43	60	31	41	60	100	100/120*	20,3	10	82,9	70	8	224000
	315	400	500													

## DIN 8167 FÖRDEYER ZİNCİRLERİ (MT SERİSİ) DIN 8167 SOLID BEARING PIN CONVEYOR CHAINS (MT SERIES)

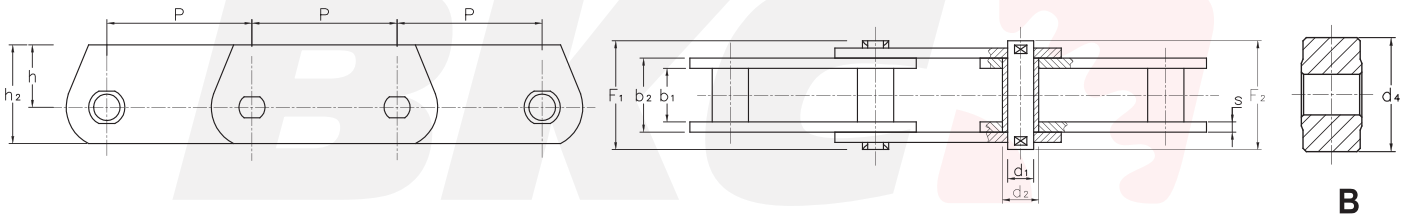

\* Döküm \* Cast iron

ISO Nr. ISO No.	p mm		b <sub>1</sub> mm min.	b <sub>2</sub> mm max.	d <sub>1</sub> mm	d <sub>2</sub> mm	d <sub>4</sub> mm B	F <sub>1</sub> mm	F <sub>2</sub> mm	h mm	h <sub>2</sub> mm	s mm	F <sub>B</sub> N min.	
MT 20	40	50	63	16	22	6	9	25	35	40	16	25	2,5	20000
	80	100												
MT 28	50	63	80	18	25	7	10	30	40	45	20	30	3	28000
	100	125												
MT 40	63	80	100	20	28	8,5	12,5	36	45	52	22,5	35	3,5	40000
	125	160												
MT 56	63	80	100	24	33	10	15	42	52	61	30	45	4	56000
	125	160												
MT 80	80	100	125	28	39	12	18	50	62	71	32,5	50	5	80000
	160	200												
MT 112	80	100	125	32	45	15	21	60	73	84	40	60	6	112000
	160	200												
MT 160	100	125	160	37	52	18	25	70	85	100	45	70	7	160000
	200	250												
MT 224	125	160	200	43	60	21	30	85	98	111	60	90	8	224000
	250	315												
MT 315	160	200	250	48	70	25	36	100	112	132	65	100	10	315000
	315	400												
MT 450	200	250	315	56	82	30	42	120	135	160	80	120	12	450000
	400	500												

Numune ve teknik resim esaslı her türlü özel zincir üretimi yapılır. *Production based on a given sample or a technical drawing.*

## DIN 8165 FÖRDEYER ZİNCİRLERİ (FV SERİSİ) DIN 8165 SOLID BEARING PIN CONVEYOR CHAINS (FV SERIES)

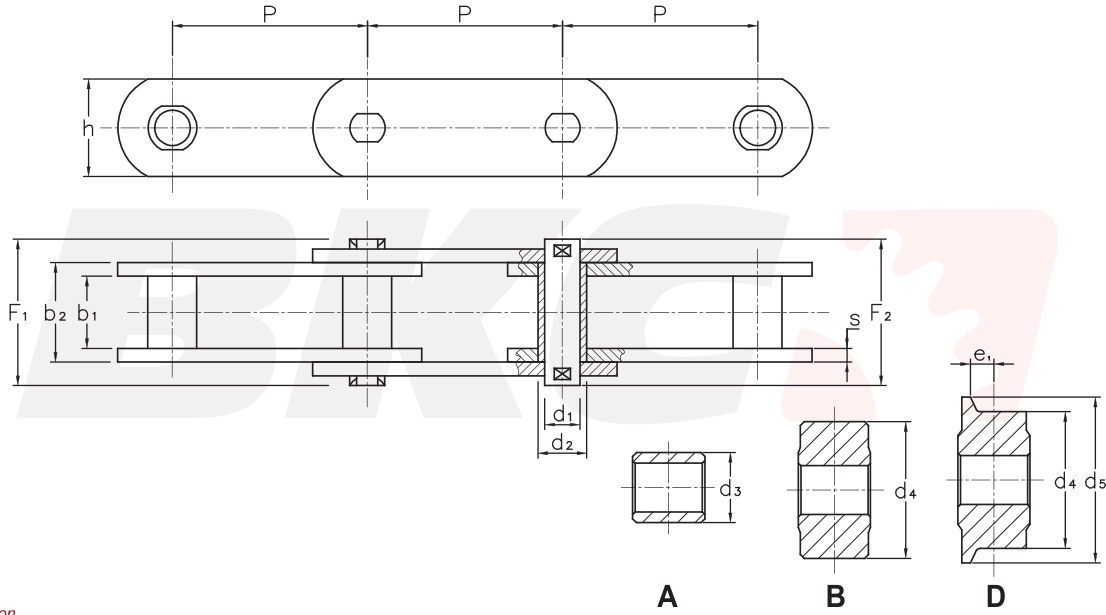

\* Döküm \* Cast iron

ISO Nr. ISO No.	p mm		b <sub>1</sub> mm min.	b <sub>2</sub> mm max.	d <sub>1</sub> mm	d <sub>2</sub> mm	d <sub>3</sub> mm A	d <sub>4</sub> mm B	d <sub>4</sub> /d <sub>5</sub> mm D	e <sub>1</sub> mm	F <sub>1</sub> mm	F <sub>2</sub> mm	h mm	s mm	F <sub>B</sub> N min.
FV 40	40	50	18	24,5	10	15	20	32	-	4,0	36,0	43	26	3	42000
	63	80							40/48						
	100														
FV 63	63		22	30,5	12	18	26	40	-	5,0	44,0	54	30	4	64000
	80	100							50/60						
	125	160													
FV 90	63		25	35,5	14	20	30	48	-	6,5	52,0	61	35	5	100000
	100	125							63/73						
	160	200													
	250														
FV 112	100		30	42,5	16	22	32	55	-	7,5	61,0	70	40	6	120000
	125	160							72/85						
	200	250													
FV 140	100		35	47,5	18	26	36	60	-	9,0	66,0	79	45	6	145000
	125	160							80/95						
	200	250													
FV 180	125		45	61,5	20	30	42	70	-	13	85,5	99	50	8	190000
	160	200							100/120						
	250	315													
FV 250	125		55	72	26	36	50	80	-	15	97,5	113	60	8	275000
	160	200							125/145						
	250	315													
FV 315	160		65	86	30	42	60	90	-	18	117	130	70	10	370000
	200	250							140/170						
	315	400													
FV 400	160		70	96	32	44	60	100	-	20	130	148	70	12	410000
	200	250							150/185*						
	315	400													
FV 500	160	200	80	106	36	50	70	110	-	21	140	160	80	12	540000
	250	315							160/195*						
	400														
FV 630	200		90	116	42	56	80	120	-	22	152	196	100	12	630000
	250	315							170/210*						
	400	500													

Numune ve teknik resim esaslı her türlü özel zincir üretimi yapılır. *Production based on a given sample or a technical drawing.*

**DIN 8165 PİM MAKARALI FÖRDEYER ZİNCİRLERİ (FVC SERİSİ)**  
**DIN 8165 HOLLOW BEARING PIN CONVEYOR CHAINS (FVC SERIES)**

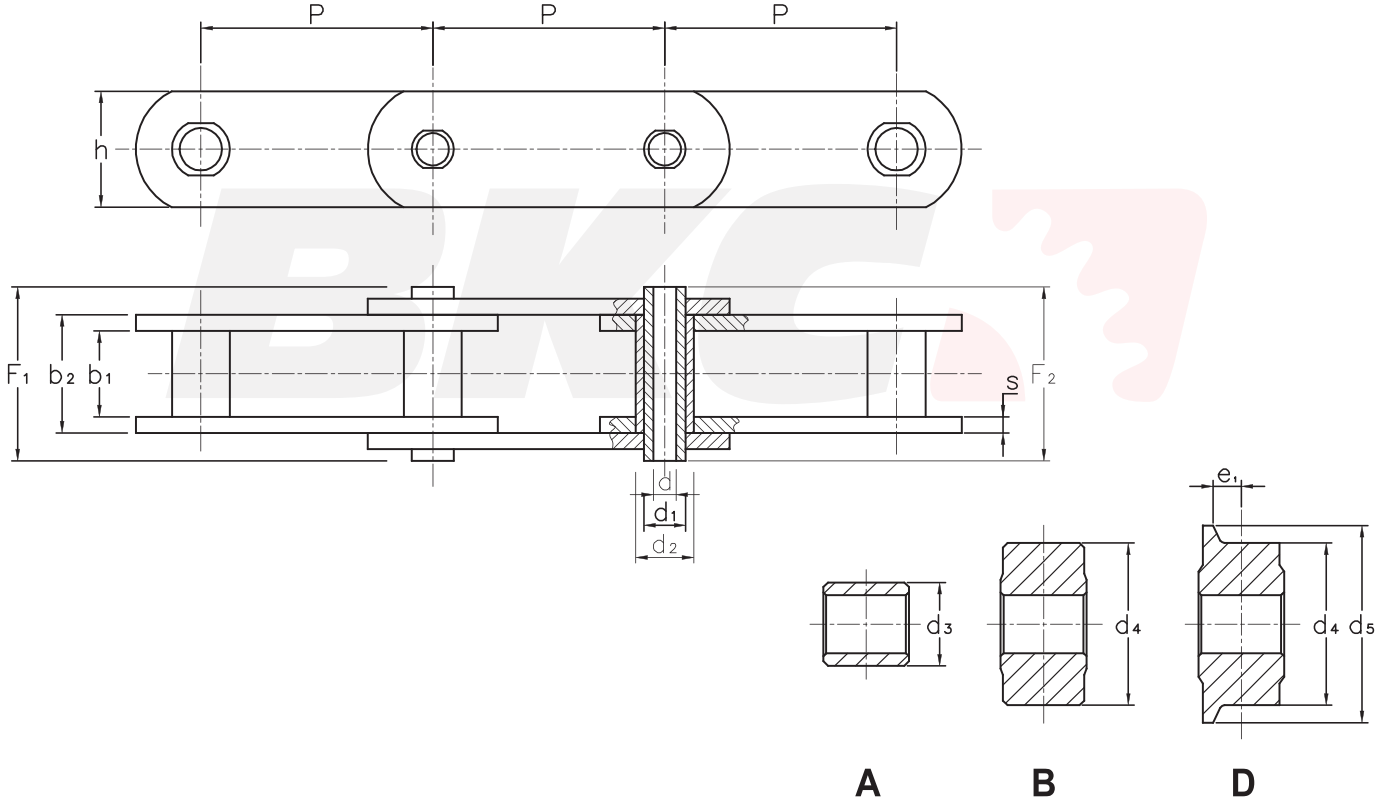

\* Döküm \* Cast iron

ISO Nr. ISO No.	p mm	b <sub>1</sub> mm min.	b <sub>2</sub> mm max.	d mm	d <sub>1</sub> mm	d <sub>2</sub> mm	d <sub>3</sub> mm A	d <sub>4</sub> mm B	d <sub>4</sub> /d <sub>5</sub> mm D	e <sub>1</sub> mm	F <sub>1</sub> mm	F <sub>2</sub> mm	h mm	s mm	F <sub>B</sub> N min.	
FVC 63	63		22	30,5	12	12	18	26	40	-	5,0	45	50,5	30	4	46000
	80	100								50/60						
	125	160														
FVC 90	63		25	35,5	14	14	20	30	48	-	6,5	53	56,5	35	5	73000
	80	100								63/73						
	125	160														
	200	250														
FVC 112	100		30	42,5	16	16	22	32	55	-	7,5	62	63	40	6	90000
	125	160								72/85						
	200	250														
FVC 140	100		35	47,5	18	18	26	36	60	-	9,0	67	68,5	45	6	110000
	125	160								80/95						
	200	250														
FVC 180	125		45	61,5	20	20	30	42	70	-	13	86	88	50	8	145000
	160	200								100/120						
	250	315														
FVC 250	160		55	72	26	26	36	50	80	-	15	97	103,5	60	8	215000
	200	250								125/145						
	315	400														
FVC 315	160		65	86	30	30	42	60	90	-	18	117	121,5	70	10	295000
	200	250								140/170						
	315	400														

Numune ve teknik resim esaslı her türlü özel zincir üretimi yapılır. *Production based on a given sample or a technical drawing.*

## FÖRDEYER ZİNCİRLERİ (FVT SERİSİ) SOLID BEARING PIN CONVEYOR CHAINS (FVT SERIES)

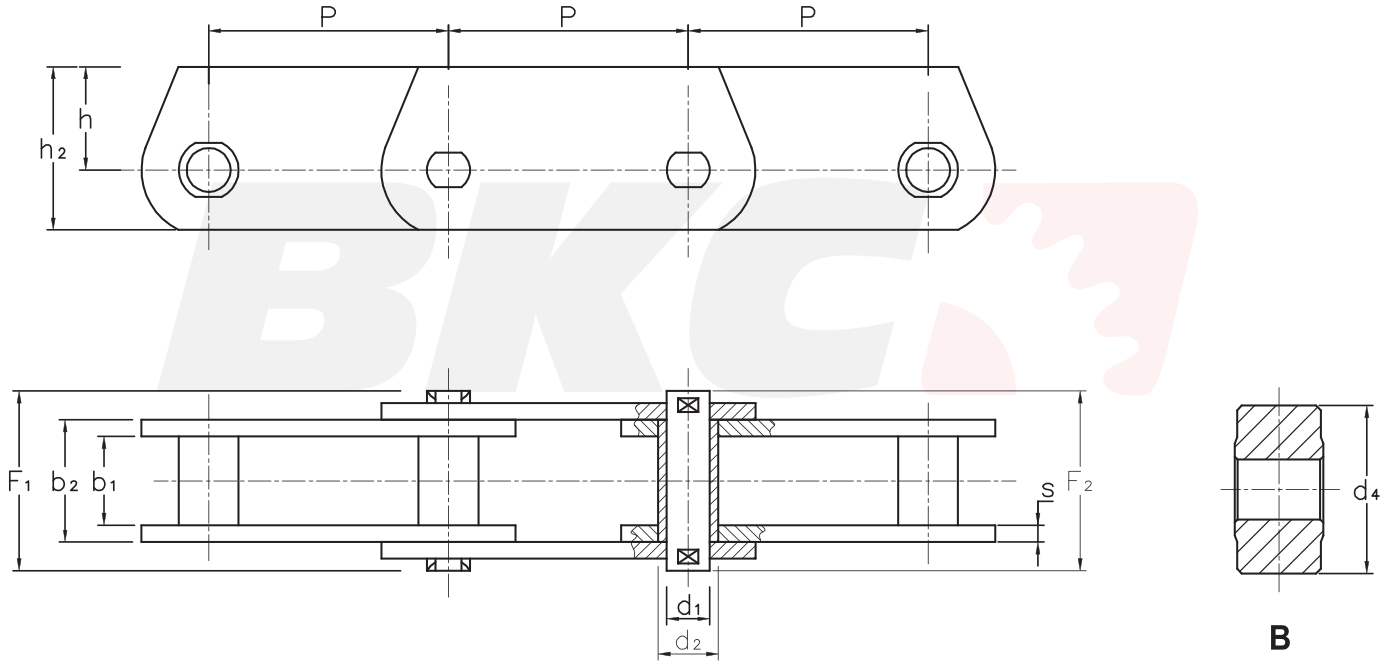

\* Döküm \* Cast iron

ISO Nr. ISO No.	p mm	b <sub>1</sub> mm min.	b <sub>2</sub> mm max.	d <sub>1</sub> mm	d <sub>2</sub> mm	d <sub>4</sub> mm B	F <sub>1</sub> mm	F <sub>2</sub> mm	h mm	h <sub>2</sub> mm	s mm	F <sub>B</sub> N min.	
FVT 40	50		18	24,5	10	15	32	36,0	43	22,5	35,0	3	40000
	63	80											
	100	125											
FVT 63	63		22	30,5	12	18	40	44	54	25,0	40,0	4	63000
	80	100											
	125	160											
FVT 90	63		25	35,5	14	20	48	52	61	27,5	45,0	5	90000
	80	100											
	125	160											
	200	250											
FVT 112	100		30	42,5	16	22	55		70	30,0	50,0	6	112000
	125	160											
	200	250											
FVT 140	100		35	47,5	18	26	60	66,0	79	37,5	60,0	6	140000
	125	160											
	200	250											
FVT 180	125		45	61,5	20	30	70	85,5	99	45,0	70,0	8	180000
	160	200											
	250	315											
FVT 250	160	200	55	72	26	36	80	97,5	113	50,0	80,0	8	250000
	250	315											
FVT 315	160		65	86	30	42	90	117	130	55,0	90,0	10	315000
	200	250											
	315	400											

Numune ve teknik resim esaslı her türlü özel zincir üretimi yapılır. *Production based on a given sample or a technical drawing.*